

UNLOAD PRO

80-1200

Lexair, Inc.®

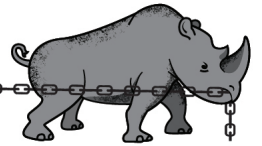

Simple. Rugged. Affordable.™

CNC Lathe Sub Spindle Part Unloader



Unload Pro Features

- Unloads sub spindle length tubing or solid parts up to 3.15" diameter (80mm) and 48" length (1.2m).
- Parts unload onto slant adjustable table or optional index conveyor.
- Standard X-axis retraction.
- Programmable servo gear motor for flexibility.
- Standard unload rod or plastic lined tube to protect delicate surfaces.
- Quickly and gently unloads parts in a safe and controlled manner.
- Designed by Breuning IRCO in Germany.
- Made in the U.S.A. by Lexair Inc.

Lexair Inc.

Problem Solved.™

www.lexairinc.com



Programmable Servo Gear Motor for speed and accuracy



Easy to use control panel

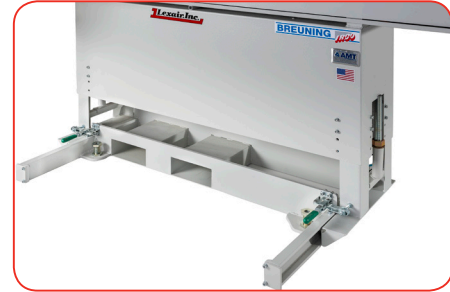

X-axis retraction is standard



UNLOAD PRO 
80-1200 Lexair, Inc.®

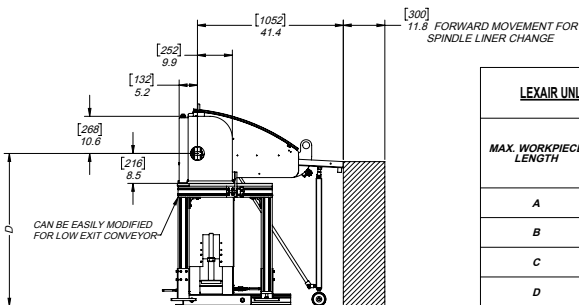

LEXAIR UNLOAD PRO 80-1200	
MAX. WORKPIECE LENGTH	47.25" [1200mm]
A	137" [3480mm] *
B	61" [1550mm]
C	80" [1905mm] *
D	DEPENDENT ON LATHE

* STANDARD DIMENSIONS

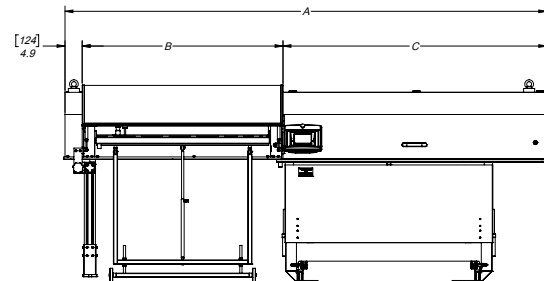
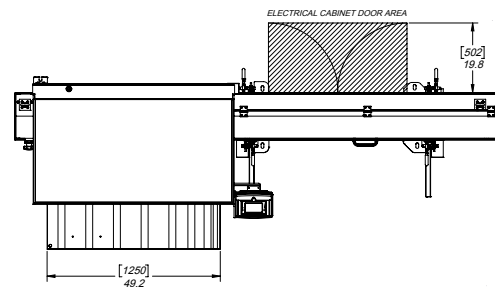

- Larger and longer part unloaders are available.
- Ask us about our large diameter (up to 130 mm or 5.25 inches) or long (up to 12 meters or 40 feet) barfeeds, bundle loaders, part and shaft loaders.
- Breuning IRCO also builds the ProfiMat, a highly productive, fully automatic multi-channel quick change magazine barfeed.



ProfiMat



Problem Solved.™
www.lexairinc.com

www.lexairinc.com

2025 Mercer Road
Lexington, KY 40511
Phone: 859-255-5001
Fax: 859-255-6656