

**Loading magazines
for precision turning of long bars**

PROFimat | ecoPROFI | SiMag | ILS-REX/TEX

POWERTURNING

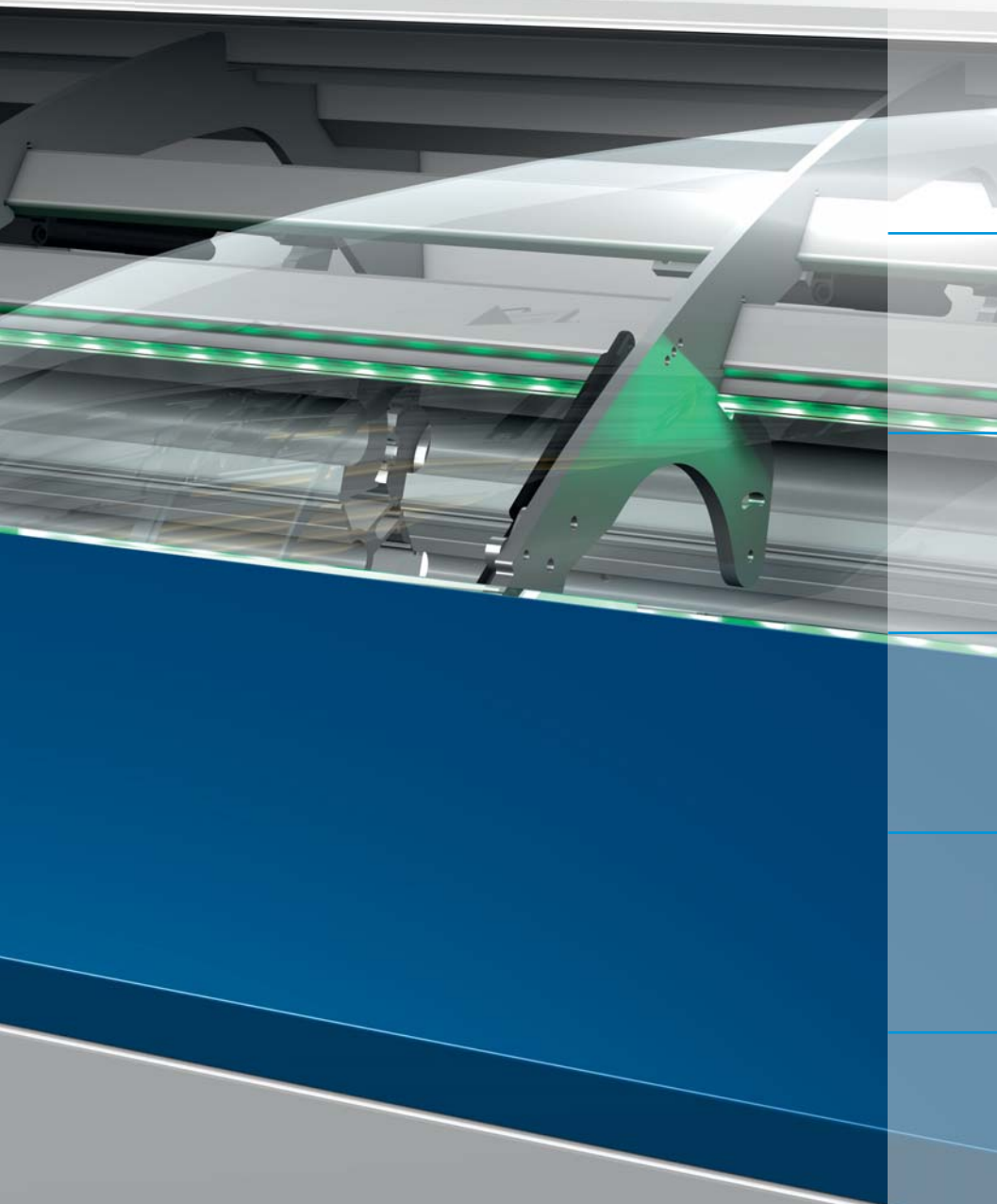



Maximum machining output through process-optimised loading and unloading, ...

High-performance turning cell for automated precision turning of long bars



IRCO multi-channel loading magazine ecoPROFI

IRCO automatic lathe unloading system ILS-REX

Get 100% performance from your lathes through non-stop loading

Breuning IRCO offers three types of loading magazines for different requirements: PROFImat, ecoPROFI and SiMag.

These loading magazines come in standard versions for bars in lengths of 3 000 mm, 4 000 mm and 6 000 mm. Special versions are also available for bars up to 10 000 mm long.

Automatic loading

The storage rack is kept "stocked" with bars. The bars get loaded into the guide channel automatically. The separator is activated when the upper guide channel segments get opened. It feeds the new bar into the guide



All Breuning IRCO loading and unloading systems are also suitable for profiled bars. An automatic insertion device ensures reliable feeding of profiled materials

channel, which is then closed again completely.

In loading magazines without remnant retraction the guide channel is loaded with a new bar while the previous workpiece is still being machined to save time.

Perfection through automatic workpiece removal

The IRCO unloading system ILS-REX and ILS-TEX are used for quick, fully automatic unloading of the workpieces "directly from the chuck".

Every lathe can be turned into a highly productive turning centre with the loading and unloading systems from Breuning IRCO.

The interfaces are prepared for the machines of all well-known lathe manufacturers or can be adapted to them.

Positioning

The bar can be positioned in the chuck against a limit stop or with the pusher (option).

The servo drive technology guarantees immediate and controlled feeding of the bar through the spindle.

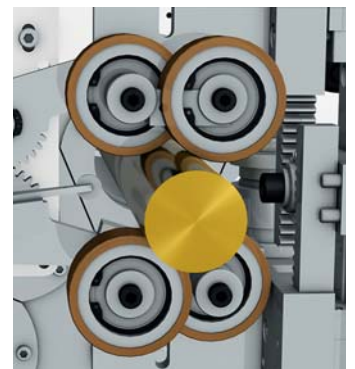

Centering steady rest between guide channel and spindle filler tube



IRCO high-performance multi-channel loading magazine PROFImat

The ideal partner for high performance lathes

The PROFImat is the ideal loading magazine for flexible, order-related turning operations. It is equipped with 8 (6) guide channels for optimum feeding of bars. The guide channels can be used in combination if required.

The PROFImat loading magazine turns powerful lathes into highly efficient production centres with low manning requirements. Other fields of application are machining centres and rotary transfer machines.

Maximum flexibility for shortest delivery periods

Since the guide channels can be changed quickly and easily, production planners are able to realise fast delivery periods. Turning from the bar with the PROFImat makes sense and is economical for even the smallest of production runs.

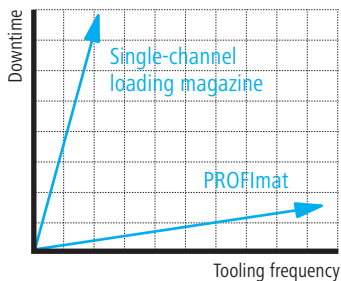

Options:

- Remnant retraction to the rear
- Electromechanical swivel device
- Positioning without stop
- Expansion of loading capacity with bundle loader
- For special requirements for positioning accuracy, appropriate systems are available on positioning accuracy
- Swivel device



The cover made of special glass enables a view onto the process in the loading magazine. For service operations the cover can be opened



The level of operation is shown via colored LED lights

Low-vibration operation through robust machine construction

The sturdy construction, wear-resistant synthetic lining of the guide channels and oil circulation (hydrodynamic padding effect) enable smooth bar rotation – even at high speeds.

Technical profile

- 8 (6) different guide channels with fast automatic change
- Guide channels with synthetic lining (wear-resistant and vibration-damping)
- Oil circulation for high speeds and low-vibration bar feeding (hydrodynamic padding effect)
- Quick guide channel changes at the press of a button
- Highly rigid, self-supporting housing
- Device for automatic feeding of rotationally symmetrical materials
- Positioning device for programmable bar starting position
- Operating terminal with touch screen
- Linear movement of the housing for changing of the spindle filler tube

Economic facts

Optimum feeding of bars by 8 (6) integrated guide channels

Top speeds with optimum concentricity (reduces the load on the machine)

Minimises machine downtimes through super-fast channel switching (at the press of a button)

Designed for three-shift operation at maximum load

The perfect loading magazine for small to medium batches

Economical production of the smallest batches



Material Ø: 5 to 130 mm

Material lengths: 3 000 / 4 000 / 6 000 (10 000) mm

Other lengths on request

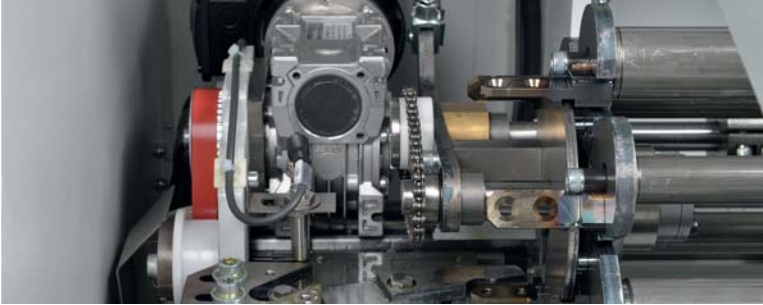

IRCO multi-channel loading magazine ecoPROFI

Suitable for all lathes

The loading magazine ecoPROFI was developed for turning workshops and sub-contractors looking for better ways to optimise flexibility, productivity and profitability.

The loading magazine ecoPROFI is designed for materials up to 50 mm in diameter. It is compatible with the machines of all well-known manufacturers. Standard lathes as well as swiss type lathes. Other fields of application are machining centres and rotary transfer machines. Up to six different guide channels can be mounted on the Gatling-Gun-Style holders.

Rational and productive

Even small batches can be turned economically from the bar.

Since it is quick to retool, the ecoPROFI loading magazine also offers all the economic advantages of the multi-channel technology in these cases.

Options:

- Remnant retraction to the rear
- Positioning without stop
- Centering steady rest
- Version for swiss type lathes



Especially designed loading flap enables reloading of bars without machine stop

Retrofittable guide channels for top flexibility

Guide channels in standard dimensions (aluminium/synthetic material) or for intermediate material diameters with synthetic material can be retrofitted at any time. The aluminium channels and channels with synthetic lining can be used in combination.

Technical profile

- 3 or 6 different guide channels with fast automatic change (aluminium/synthetic lining)
- Initial version with three guide channels for future expansion to six channels
- Oil circulation for high speeds and low-vibration bar feeding (hydrodynamic padding effect)
- Quick guide channel changes at the press of a button
- Highly rigid, self-supporting housing
- Device for automatic feeding of rotationally symmetrical materials
- Positioning device for programmable bar starting position
- Operating terminal with touch screen
- Linear movement of the housing for changing of the spindle filler tube
- Suitable for long automatic lathes. Synchronizer and telescope system for optimum material guidance

Economic facts

The modular design enables gradual conversion from a single-channel to a multi-channel loading magazine

Recommended initial configuration with 3 guide channels as inexpensive „starter kit“

Other guide channels – adapted to the particular material – can be added at a later date

Thanks to the short channel switching times, the flexibility of the machine can also be used for small batches

High profitability and quick amortisation of investment through utilisation of the maximum productivity of the lathe

*Ideal for the first step
into the multi-channel league*



Material Ø: 5 to 50 mm
Material lengths: 3 000 / 4 000 / 6 000 mm
Other lengths on request



IRCO single-channel loading magazine

SiMag



Universal

The single-channel loading magazine is suitable for loading of all lathes. Standard as well as swiss type.

Other fields of application are machining centres and rotary transfer machines.

Options:

- Remnant retraction to the rear
- Long turning version (L version)
- Spindle synchronizing (electronically)

Note:

Also available as material feed system for machining centres

Quick change technique

Thanks to the clip technique used, the guide channel segments can be changed quickly and easily.

This reduces tooling times considerably.

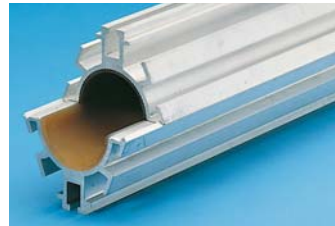
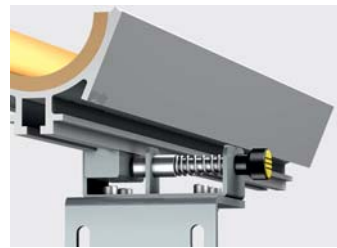

Two-part guiding segment of aluminium with highly wear-resistant synthetic lining. Also enables the machining of black bar stock

Steady rest

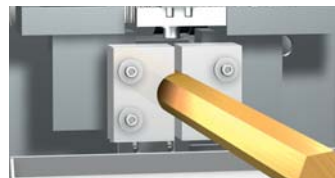

Top picture:
Settings for round material $\varnothing > 22$ mm

Bottom picture:
With jaws for profiled material and round material $\varnothing < 22$ mm

Technical profile

- Manually changeable guide channel with synthetic lining (wear-resistant and vibration-damping)
- Quick channel changes through clip fasteners
- Oil circulation for high speeds and low-vibration bar feeding (hydrodynamic padding effect)
- Highly rigid, self-supporting housing
- Device for automatic feeding of rotationally symmetrical materials
- Positioning device for programmable bar starting position
- Operating terminal with touch screen
- Linear movement of the housing for changing of the spindle filler tube
- Centering steady rest
- Loader is barely longer than bars
- Precise positioning without limit stop

Economic facts

High-quality single-channel loading magazine with high-tech guide channel for maximum production loads

The robust design enables vibration-free processing of bars up to 160 mm in diameter and 6 000 mm in length. The use of longer bars reduces the amount of remnant

Top profitability for medium and especially for large production batches

Other guide channels can be ordered when needed

Optimised for medium to large lot production



Material \varnothing : 5 to 130 mm
Material lengths: 3 000 / 4 000 / 6 000 mm
Other lengths on request



IRCO automatic lathe unloading magazine ILS-REX + ILS-TEX

Unloading workpieces quickly in a fully automatic and gentle manner

The rapid unloading technology brings about a continuous flow of material and enables the lathe to develop its full power. The extraction happens without opening the machine door.

The ILS-REX can be used with a single as well as with a counter-spindle lathe. A more automated parts concatenation with handling machines and magazines can also be delivered.

Reliable workpiece removal directly from the clamping device

The automatic, process-integrated removal of workpieces directly from the clamping device allows the systematic optimization of cycle times.

With three different types of standard elements taking up the workpieces (unloading tube, clamping sleeve and internal clamping device) it is possible to gently, safely and quickly to unload almost any workpiece.



Unloading pusher with clamping sleeve for removing workpieces from the clamping device and positioning them onto the indexed conveyor

Workpiece positioning

For simple workpieces, a chute is used (ILS-REX).

For complex shapes, sensitive or non-linear rolling workpieces, a horizontal indexed conveyor is used (ILS-TEX).

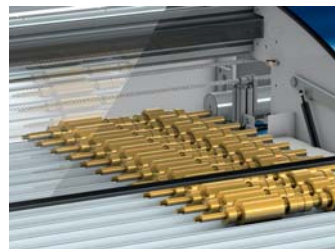

ILS-TEX unloading system with indexed conveyor

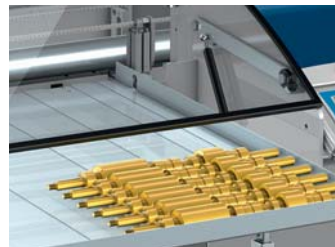

ILS-REX unloading system with chute

Brief technical profile

- Fully automatic unloading of short and long workpieces
- Various unloading devices are available:
 - > Unloading tube
 - > Clamping sleeve
 - > Internal clamping device
- Optimal adaptation to the respective unloading tasks thanks to a servo drive with independent control of feed force and speed
- Graphic display with touch screen
- Interface to the machine
- Radial displacement of the housing for the change of spindle filler tubes
- Particularly suitable for counter-spindle lathes
- Gentle, axial access to the workpiece
- No machine stop due to opening the machine door

Accessories / Options:

- Spindle filler tubes
- Clamping sleeves, clamping device
- Bus interface

Economic facts

The automatic workpiece removal is an important criterion for an optimized turning process

In counter-spindle lathes, the counter spindle can be unloaded while the machining process is carried out on the main spindle

With the combination of Breuning IRCO loading and unloading systems, the workpiece output can be increased significantly

The tried and tested unloading technology ensures gentle handling of the workpiece

ILS-REX 80 / 100
ILS-TEX 80 / 100
Material Ø: max. 80 / 100 mm
Workpiece lengths: 800 / 1 200 mm
Other material lengths on request





... minimum tooling times, turning processes without machine stop

Time saving through super-fast changeover of guide channels

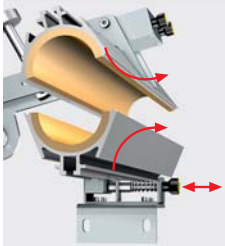

The single-channel loading magazine SiMag uses clip fasteners to allow quick manual changing of the guide channel without the need for tools

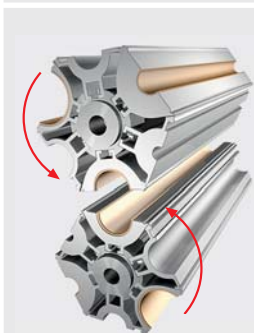

In the multi-channel loading magazines PROFImat and ecoPROFI channel changes are carried out in a matter of seconds at the press of a button

Closed guide channel

A guide channel consists of several segments, which open step-by-step for the pusher.

The guide channels come in fine graduations for optimum guiding of different bars.

Optimum utilisation of bars

There are two possibilities available for positioning of the bars in the lathe:

1. Positioning without limit stop
2. Positioning with limit stop > quick and very accurate

The control system of the loading magazine ensures a minimum remnant length.

Process control

The control system monitors all sequences in the loading systems to ensure a reliable process.

Hydrodynamic bar guiding

Oil is circulated through the guide channel continuously.

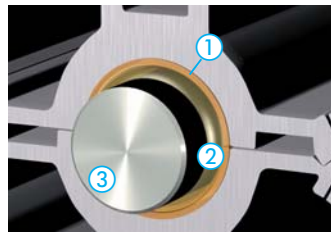

- ① Anti-vibration plastic coating
② Oil cushion ③ Bar stock

This and the rotating bar produce a hydrodynamic padding effect, which stabilises the bar in the channel. This results in optimum concentricity in bar rotation, which reduces the load on the machine spindle.

The oil padding bridges diameter increments and ensures low friction and almost vibration-free guiding of the bars in the channel.

Breuning IRCO recommends use of a tight-fitting guide channel for precision jobs.

Spindle filler tube as extended guide channel

Spindle filler tubes matched to the guide channel guarantee optimum guiding of the bar in the machine spindle.

The spindle filler tubes can easily be changed by swinging the magazine housing in linear direction.

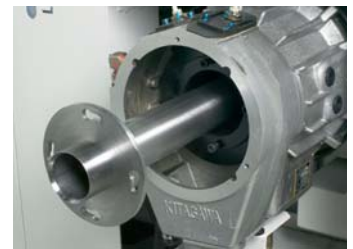

Spindle filler tubes can be delivered for every lathe

Remnant removal

The remnant of a bar is either pushed into the lathe or removed by the magazine.

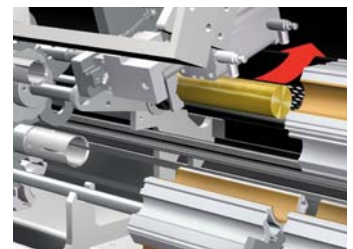

Automatic disposal of the bar remnant by optional remnant retraction



ecoPROFI loading magazine with open cover to show the storage rack and the guide channel with synthetic lining



Further products from the IRCO range

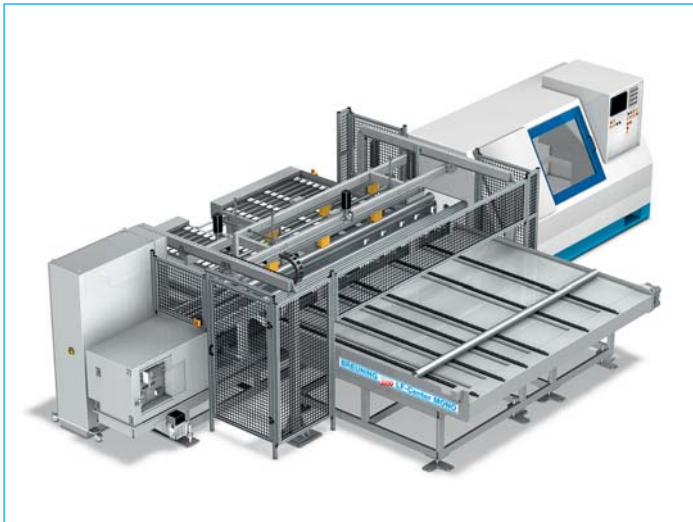

Steady rest centre MONO

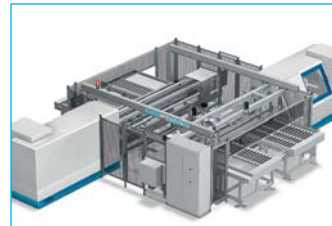

Steady rest centre DUO



Steady rest centre ROTO

Technological advice from the manufacturer

Breuning IRCO offers expert knowhow and competence – acquired in over four decades of work in the industry – for rational precision machining processes with a range of perfectly matched loading and unloading equipment.

If you are thinking about automating your turning operations, we recommend you contact us early on in your project for orientation talks with our technology consultants so that you can fully exploit the often hidden resources of modern lathes and machining centres for automation. On request we will gladly also compile a concrete profitability calculation for you.

The application reports in our magazine THE REPORT ON EXPERIENCE provide insights into specific solutions for different aspects of process automation. Contact us for further information or visit us on the Internet at breuning-irco.com



IRCO multi universal short-bar automatic loader ILS-MUK 70
Material Ø: 6 to 76 mm
Material lengths: 1 200 / 1 600



IRCO spindle liner tube
– Ready to install
– Aligned and balanced
– Fits exactly
– Surface protection (optional)

Kurt Breuning IRCO Maschinenbau GmbH



Im Maurer 15
71144 Steinenbronn
GERMANY
Fon: +49 7157 52860
Fax: +49 7157 528655
technologie@breuning-irco.de
breuning-irco.com

